

TRACHTE CONVERSION SYSTEM OPTIONS

- CONVERSION SYSTEM HEIGHTS – Carefully consider the needed height for overhead HVAC, electric, and sprinklers. At least 2'-0" of working space, above a system, is suggested for installation of wire mesh security. See Table 1A for available system heights and corresponding door openings.
- UNIT/DOOR OPENINGS – Each system is designed and manufactured to include Trac-Rite® roll-up and swing doors. Trachte standard starter jambs are 8" and double jambs are 16". Depending on the system height and width, flush and/or corrugated swing doors may be needed. See Table 1A for available door opening heights and corresponding system heights.
- UNIT CORRIDOR WALLS – A unit corridor wall is a run of finished wall, along a unit, with no doors. Trachte provides either 26 gauge 20" wide rigid rib panel or 24 gauge 12" wide flush panels. The flush panels are an upgraded product with greater durability.
- UNIT PARTITION WALLS – A unit partition wall is a run of finished wall, separating units, with no doors. Trachte provides 29 gauge 36" wide Galvalume PBR corrugated panel. Trachte can provide 26 gauge 20" wide rigid rib panel as an available option.
- COLOR OPTIONS – Corridor walls and corridor trim throughout a conversion system are bright white. Partition walls and partition trim located inside units are galvalume in color. The roll up doors and corrugated inserts in swing doors are available in a variety of different colors (contact Trachte for up to date list of available colors).
- WIRE MESH SECURITY – Horizontal wire mesh with required supports provides added security above units.
- BURGLAR BAR SECURITY – Burglar bars, mounted between the system and existing ceiling, are available for added security over corridor walls, headers, and partition walls.
- DIAMOND PLATE ACCESSORIES – Trachte manufactures multiple optional diamond plate accessories.
 - Kick plates - For additional protection on corridor walls from platform cart damage.
 - 4'-0" tall corner guards - Attaches over standard full-length white trims for extra protection.
 - Full system height corner guards - Are installed in place of typical corner trim.
 - Full system height chamfered corner guards - Manufactured with a 45° angle chamfer and is installed in place of typical corner trim.
 - 1'-0" tall door jamb guards - Manufactured to fit over door jambs between units for additional protection.
- LINER PANEL – Trachte manufactures panel that can mount to existing walls to create a clean finished look. Liner panel can be system height and/or full floor to ceiling height.
 - 29 gauge 36" wide Galvalume PBR corrugated panel, is typically located inside units.
 - 26 gauge 20" wide rigid rib panel, is typically located on exposed corridor walls.
 - 24 gauge 12" wide semi-flush panel, is typically located on exposed corridor walls.
- EXPOSED SCREWS – Within a conversion system, there may be some exposed screw points inside storage units. Protective screw caps are available at additional cost, not included with a standard system.

GUIDELINES FOR DESIGNERS

- HALLWAY/CORRIDOR WIDTHS – typically 5'.
- UNIT SIZES – Self storage units are typically built to fit on a 5' grid line. Keeping units to standard nominal sizes such as 5x5, 5x10, 10x10, etc. will greatly simplify the installation process. When working with an existing space that is not divisible by 5, add the extra space to a single unit at the end rather than dividing equally among an entire row of units. For example, if you were building 10x10 units along a 41' long space, make the last unit 11' wide.
- ADA COMPLIANCE – Storage properties must have ADA units totaling 5% of the first 200 units plus 2% of additional units. The ADA guidelines may require swing doors, pull straps, and latch modifications. ADA guidelines may vary by area.
- SPRINKLERS – Check with local officials on sprinkler guidelines. Existing sprinkler systems may need to be revised during renovation.
- EGRESS CONCERNS – Building code may prohibit dead end hallways/corridors greater than 20', or greater than 50' in buildings where sprinklered. These requirements may vary by area.
- MULTI STORY EGRESS – Two independent, fire rated stairways are typically required for egress from an upper level. These will typically require direct access to the outside.
- MULTI-STORY LAYOUT – In buildings with existing head room of 18' or greater, a two-story conversion system may be possible. The lower level walls will be load bearing. These walls are typically placed perpendicular to the longest dimension of the existing space and placed every 10'. Upper level walls should be located directly over the lower level walls as much as possible.
- LIGHTING – Lighting requirements may vary for ease of future maintenance. Groups of motion activated LED are typically used.
- HVAC – Self Storage properties are typically kept from around 50-80 °F (10-27 °C). Trachte recommends the use of central dehumidification systems.
- BUILDING COLUMNS – The ideal layout will be designed so that existing building columns are inside the storage units, not in hallways.

CORRIDOR PANEL AND DOOR INSTALLATION SUMMARY

- Refer to the Trachte Erection Manual for complete detailed documentation to efficiently erect a Trachte Create-A-Space self-storage system. Trachte prepares erection drawings specifically for the partition system(s) you receive which contain dimensions, details, descriptions and installation details of accessories and optional items ordered from Trachte. These plans and details, along with the descriptions and illustrations in this guide, provide you with complete instructions necessary for the job.
- Unload and inspect the shipment using the bill of lading and picking tickets for missing items or damage to components and/or hardware. Note any damaged items or components BEFORE the truck leaves the site. Promptly report these components to Trachte customer service.
- To simplify and expedite erection of the storage system, separate each group of materials and components by part number and size.
- When satisfied with the overall length and width of the existing space, proceed with laying out the partition and corridor system.
- Before starting assembly, take time to carefully study the job specific plans and details, as it will help to better understand what components are required.
- Locate a starting existing structure corner, preferably one that is square. Using the provided job specific plans for reference, snap a chalk line down the unit corridor. Keep square with the existing wall.
- Locate and mark each bay interval and snap a chalk line across the floor on each set of marks.
- Locate and install baseplates by positioning the front edge of the baseplate to lie 1/32" back from the corridor line. Center roll-up base plate on partition line. Cut a roll-up base plate in half to install a single/starter jamb. Base plates vary in length to match the jamb width. Continue down the corridor line locating jamb baseplates per job specific plans.
- Layout and fasten a door frame assembly, face down, on a sheet of cardboard to prevent scratching. Position door header to line up with the punched holes on the doors jambs and fasten from header into door jambs.
- Position the door frame assembly upright so that it can be set in place and attached to the jamb baseplates. Verify door opening is plumb and square, then fasten.
- If at an existing wall, use an outside corner angle fastened to existing wall to attach the door frame assembly. FASTENERS BY OTHERS.
- If at a freestanding corner attach door frame assembly to adjacent corridor wall panel.
- Continue assembly of the corridor (door) wall and any blank wall per plans.
- Locate and install corridor wall panel, flush or rigid-rib, per plans. Corridor wall panel can be used at adjacent corridors, in place of door assembly or as spacer panels between the doors.
- Fasten the bottom channel to the floor with at least 2 fasteners on 36" center. FASTENERS BY OTHERS.
- Install the brighter side of the panels facing the corridor. Place the first panel into the channel, when flush with the adjoining jamb, fasten the flange to the door jamb from behind.
- Continue corridor panel assembly of the corridor (door) wall and any blank wall per job specific plans.
- Install the top track in lengths as the wall is constructed to keep the wall straight. Top track is fastened above corridor panel and door headers every 24 inches.

SYSTEM HEIGHT	DOOR OPENING HEIGHT
7'	6' 8" swing doors only
7' 6"	7' swing doors only
8'	6' 8" roll-up doors or 7' swings
8' 4"	7' roll-up doors
8' 6"	7' roll-up doors
9'	7' roll-up doors
9' 6"	7' roll-up doors
10'	7' roll-up doors

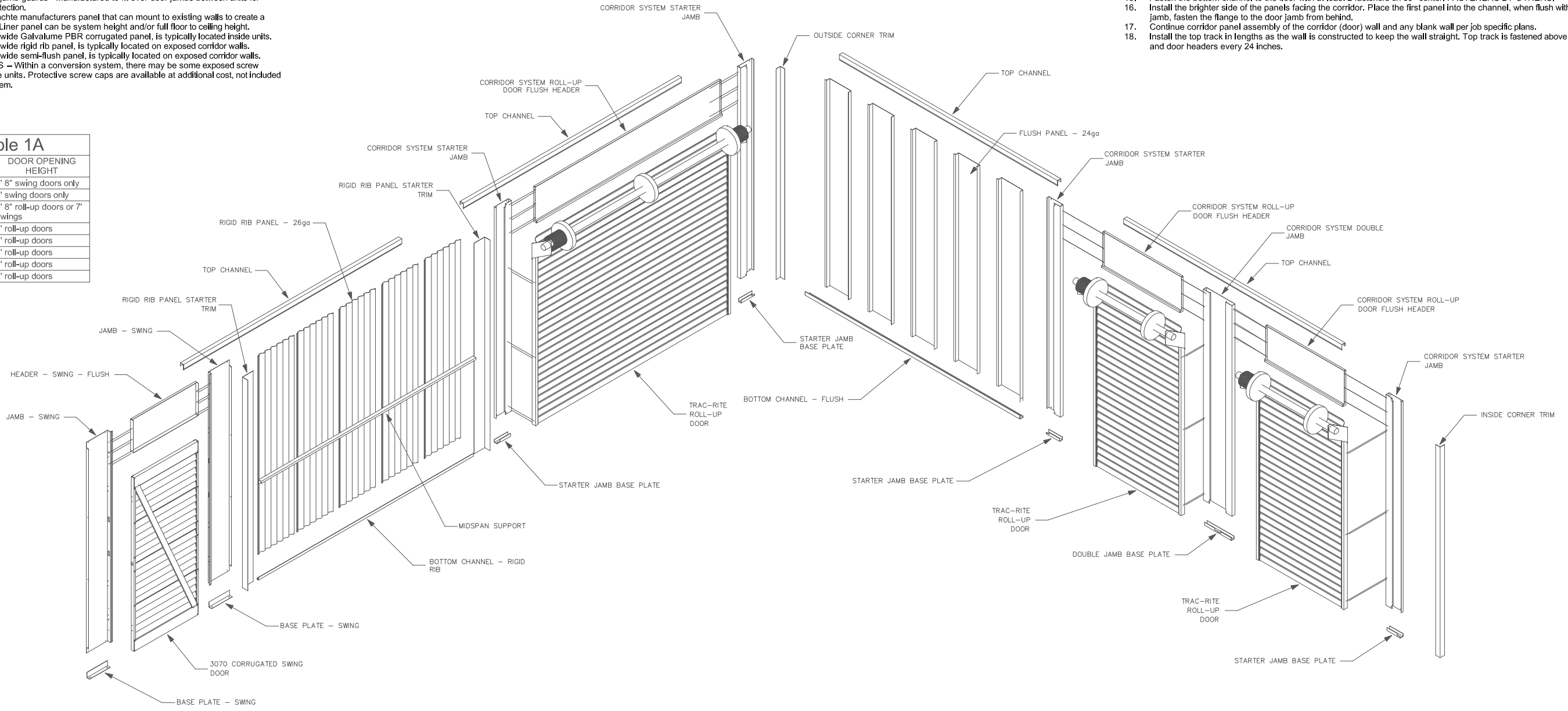

1 TRACHTE WALL CORNER

Revision	By	Date

TRACHTE BUILDING SYSTEMS, Inc.
 This drawing and all parts thereof
 is the exclusive property of
 Trachte Building Systems, Inc.
 314 Wilbur Road, Sun Prairie, Wisconsin
 and may not be reproduced in whole
 or part without written permission.



Trachte Building Systems
 314 Wilbur Road
 Sun Prairie, WI 53590

TRACHTE CORRIDOR PANEL AND DOOR ISOMETRIC

2/22/2024
 ELZ
 1/2" = 1'-0"

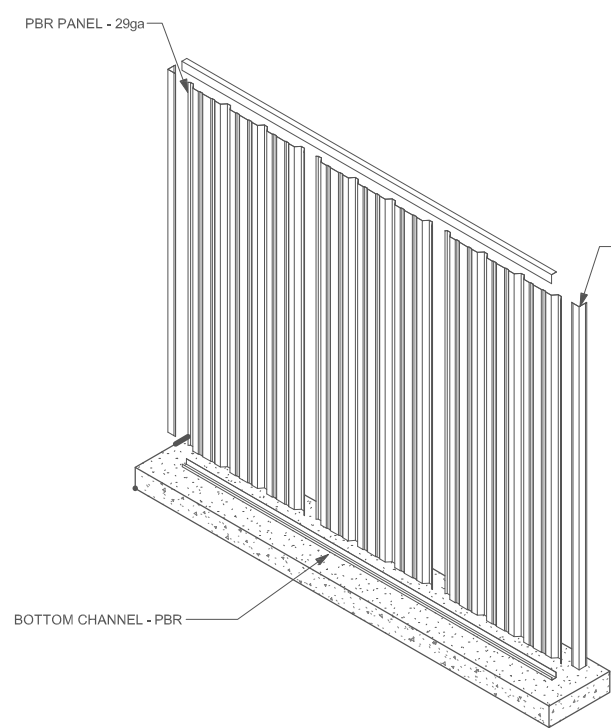

1 TYPICAL PBR PANEL ASSEMBLY

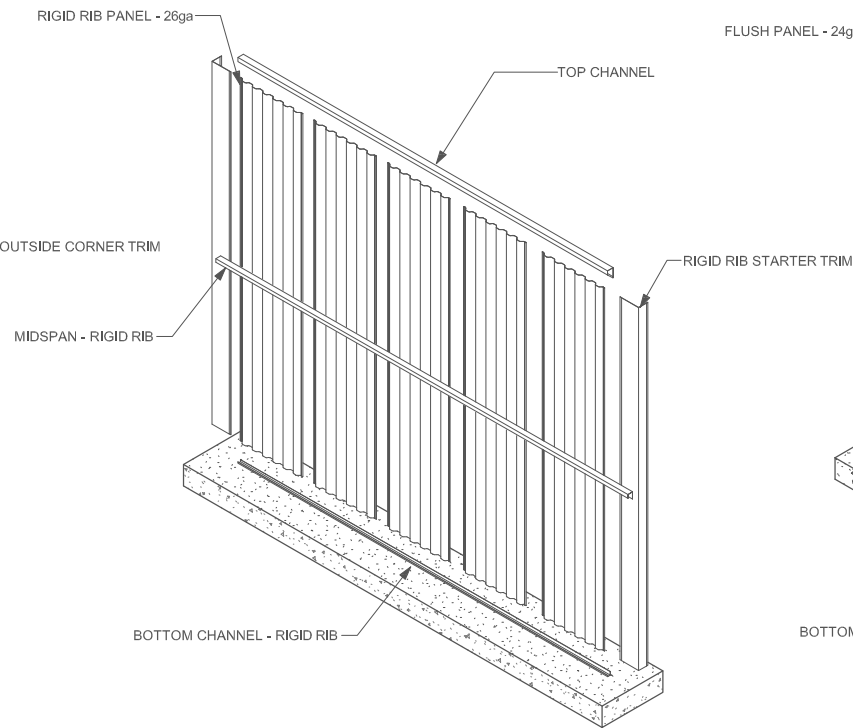

2 TYPICAL RIGID-RIB PANEL ASSEMBLY

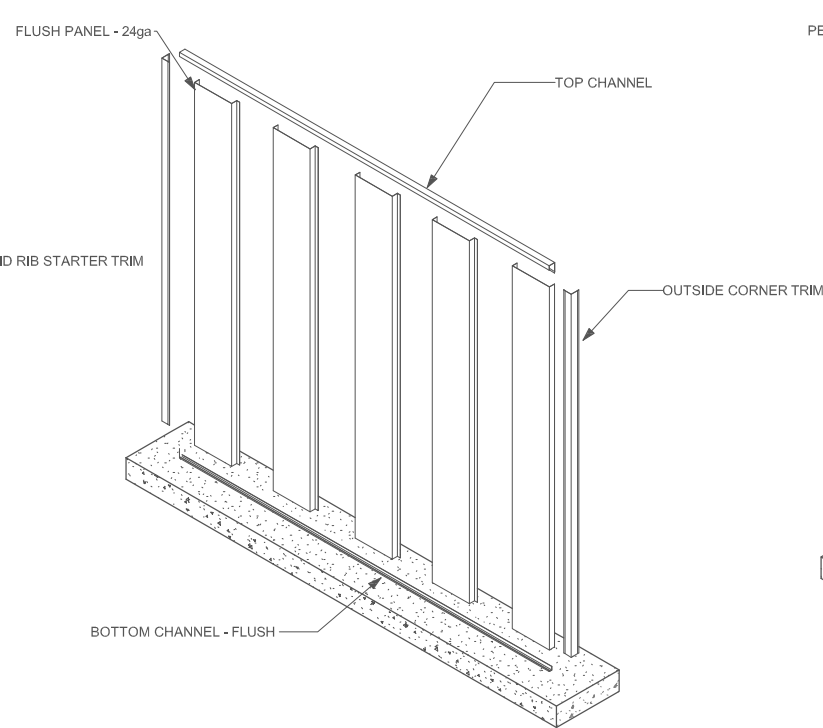

3 TYPICAL FLUSH PANEL ASSEMBLY

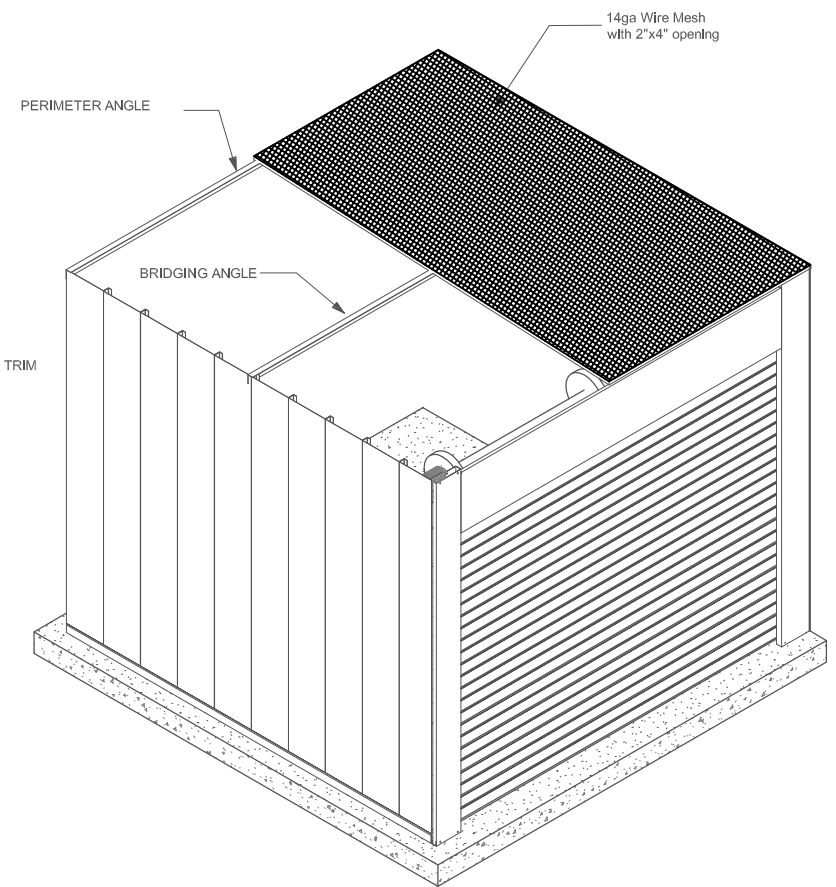

8 WIRE MESH SECURITY

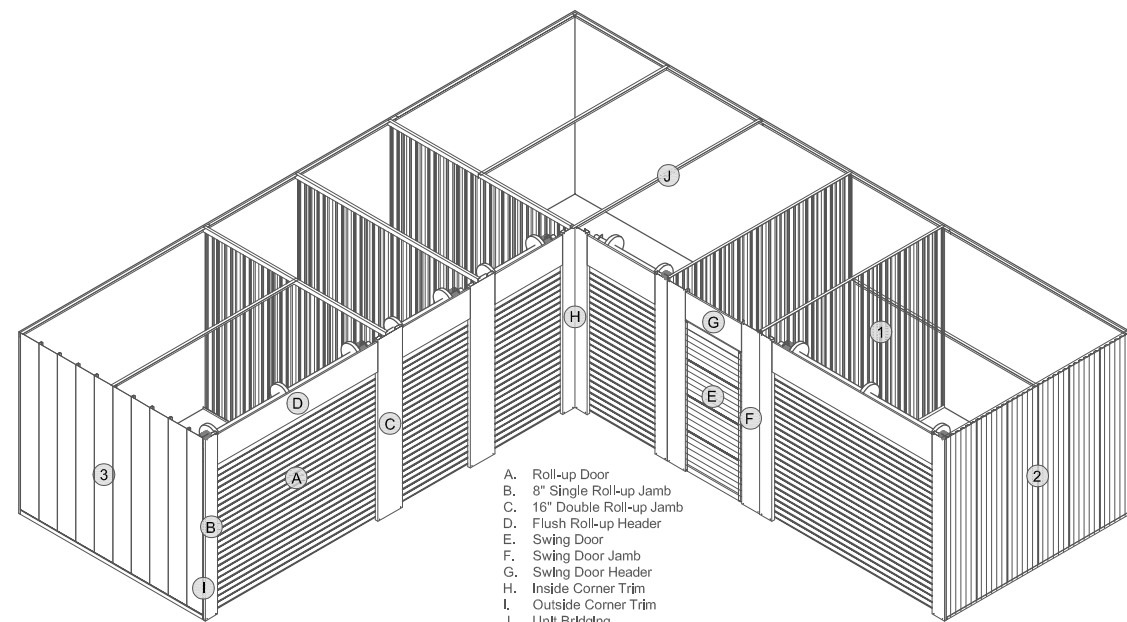

- A. Roll-up Door
- B. 8" Single Roll-up Jamb
- C. 16" Double Roll-up Jamb
- D. Flush Roll-up Header
- E. Swing Door
- F. Swing Door Jamb
- G. Swing Door Header
- H. Inside Corner Trim
- I. Outside Corner Trim
- J. Unit Bridging

- 1. Interior Wall Partition Panel
- 2. Corridor Wall Rigid-Rib Panel
- 3. Corridor Wall Flush Panel

TYPICAL CONVERSION CORNER

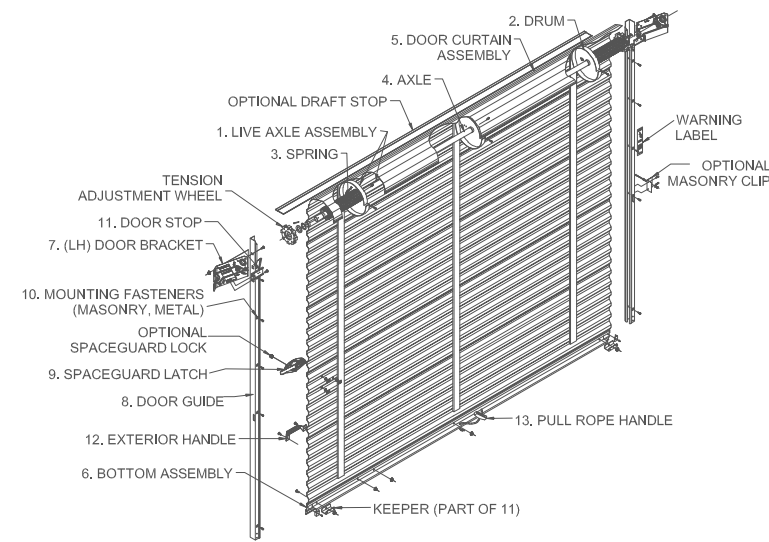

A TRAC-RITE 944 DOOR ASSEMBLY

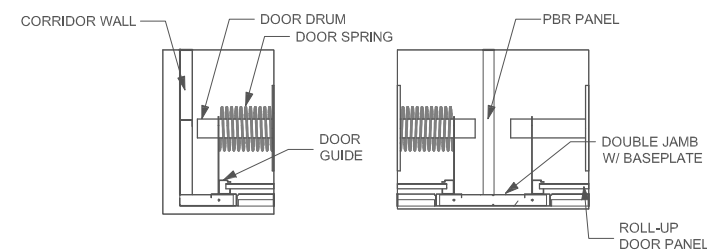

DOUBLE SMALL ROLL-UP DOOR SECTIONS

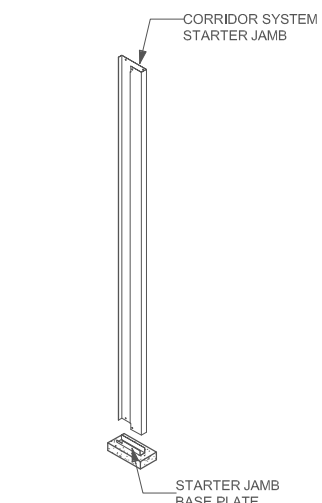

B STARTER JAMB

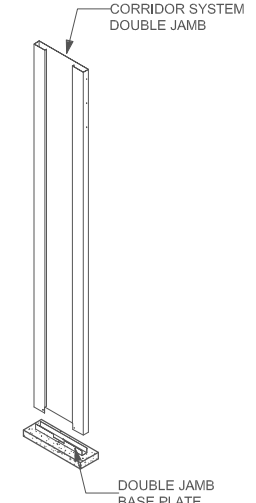

C DOUBLE JAMB

Revision	By	Date

TRACHTE BUILDING SYSTEMS, Inc.
This drawing and all parts thereof
is the exclusive property of
Trachte Building Systems, Inc.
314 Wilbur Road, Sun Prairie, Wisconsin
and may not be reproduced in whole
or part without written permission.



Trachte Building Systems
314 Wilbur Road
Sun Prairie, WI 53590

TRACHTE CONVERSION SYSTEM

02/23/2024

ELZ

1/2" = 1'-0"

A2.0

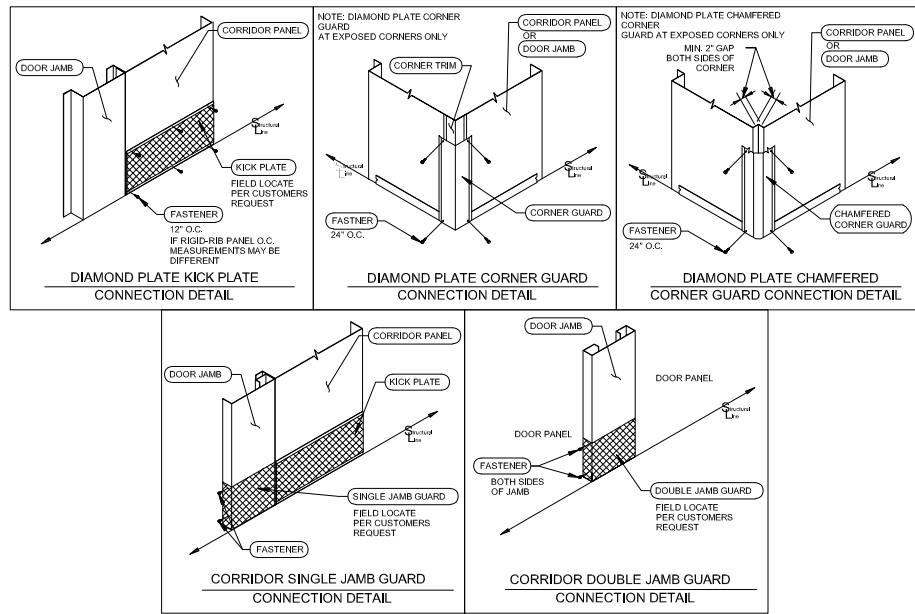

DIAMOND PLATE OPTIONS
(WALL CONSTRUCTION MAY VARY)

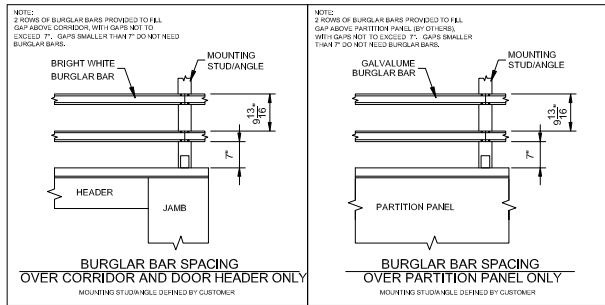

BURGLAR BAR OPTIONS
(WALL CONSTRUCTION MAY VARY)

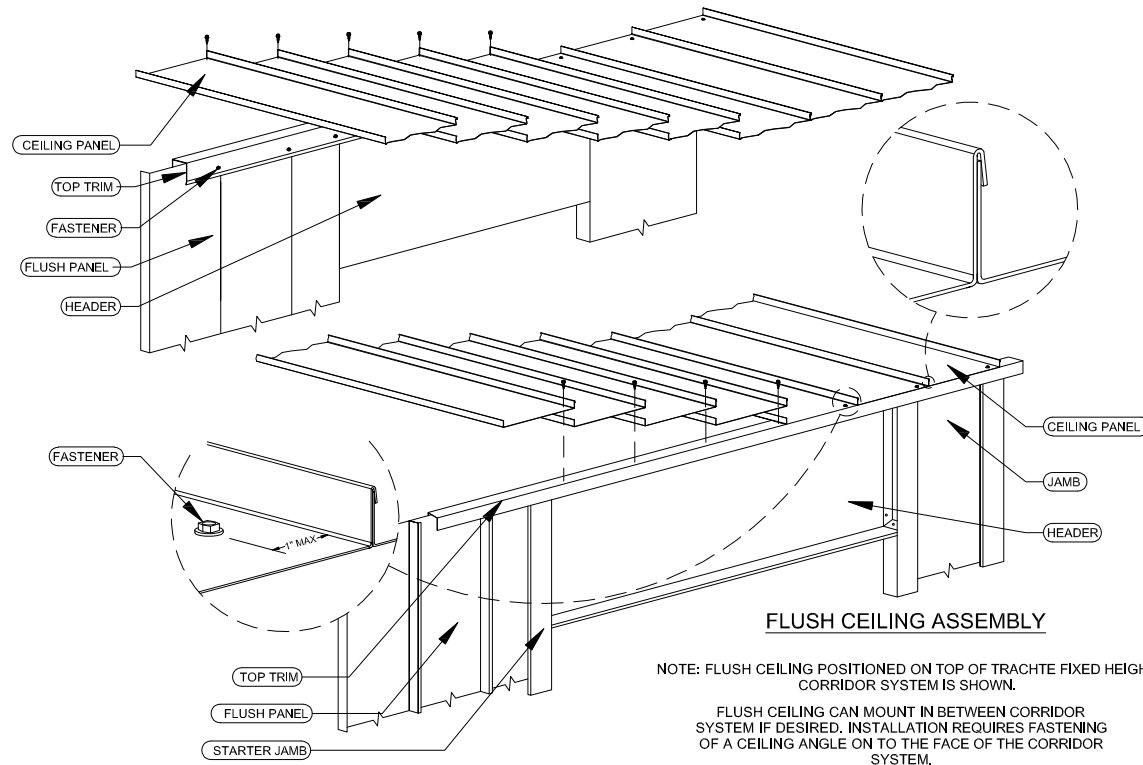

TYPICAL CORRIDOR FLUSH CEILING PANEL OPTION DETAIL
(WALL CONSTRUCTION MAY VARY)

(Halfway ceiling installation may affect sprinkler installation/coverage)

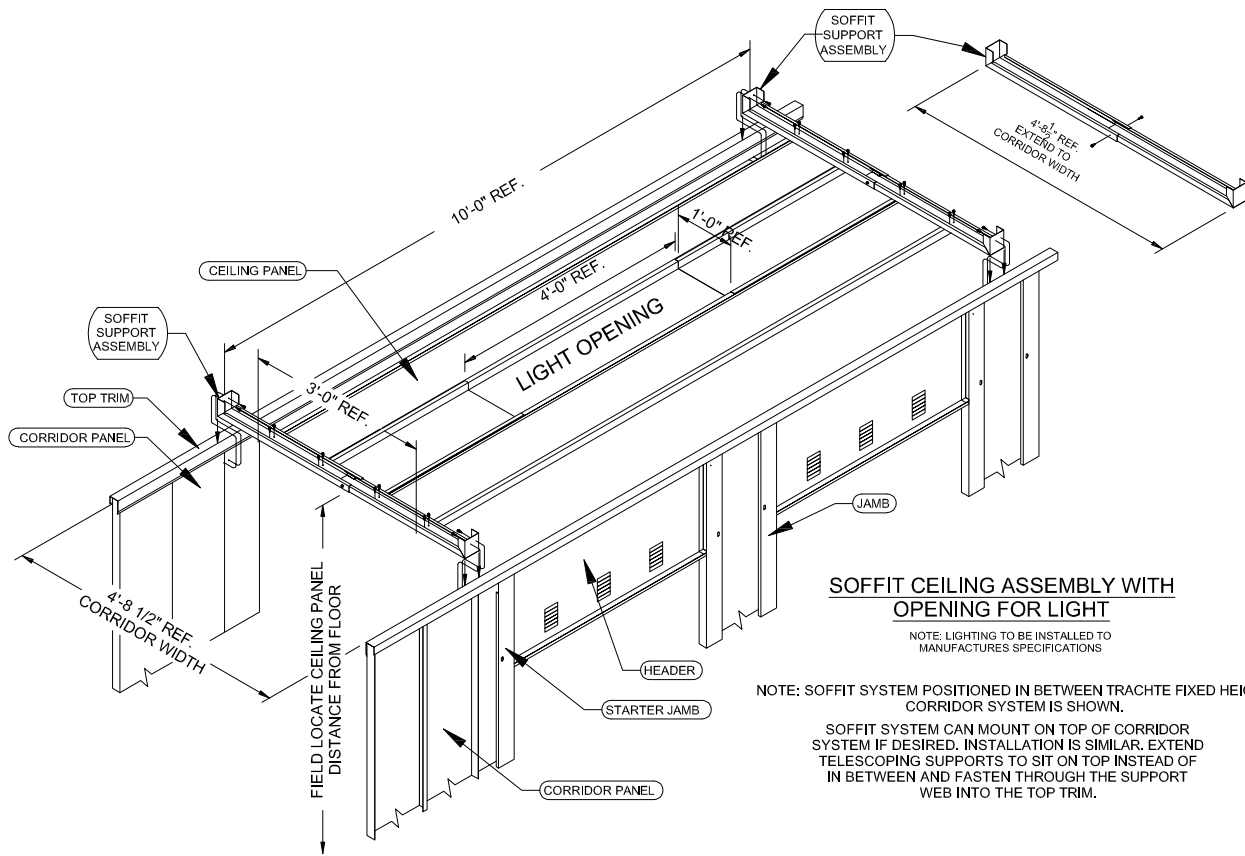

TYPICAL CORRIDOR SOFFIT CEILING PANEL OPTION DETAIL
(WALL CONSTRUCTION MAY VARY)

Revision	By	Date

TRACHTE BUILDING SYSTEMS, Inc.
This drawing and all parts thereof
is the exclusive property of
Trachte Building Systems, Inc.
314 Wilbur Road, Sun Prairie, Wisconsin
and may not be reproduced in whole
or part without written permission.



Trachte Building Systems
314 Wilbur Road
Sun Prairie, WI 53590

TRACHTE CONVERSIONSYSTEM ACCESSORIES

02/23/2024
ELZ
1:1